

NOYES

Design Guide

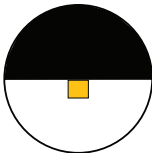

Ceiling

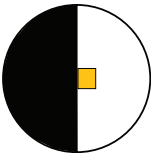

Wall

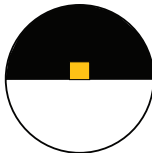

Recessed

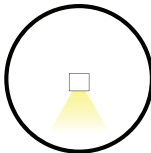

Direct
Symmetric



PROFILE DIMENSIONS

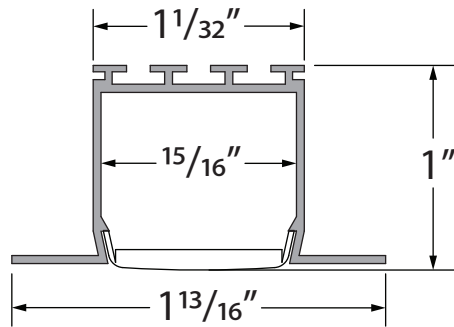

AVAILABLE TIVOTAPE™ OPTIONS

SB	XS	HO	HD	ELITE	VHO	Tunable White	RGB	RGBW
2200K	2400K	2700K	3000K		3000K	3500K		
	3500K	4000K	5000K			2200K	3000K	
						2700K	4000K	
						2200K	6500K	

ORDERING INFORMATION

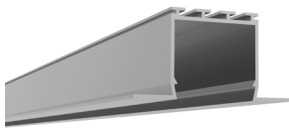

NOYS-CHAN-SLV-6.5
Anodized Aluminum Extrusion,
available in 6.5' lengths



NOYS-LNS-OPL-6.5
Lens, opal, length 6.5'

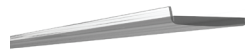

NOYS-LNS-CLR-6.5
Lens, clear, length 6.5'



NOYS-LNS-DIF-6.5
Lens, diffuser, length 6.5'



NOYS-EC-01
Solid End Cap



NOYS-EC-02
Powerfeed End Cap



NOYS-SPRING-CLP
Clip, Spring, Metal

PHOTOMETRICS BASED ON 3000K/HO/ELITE TIVOTAPE

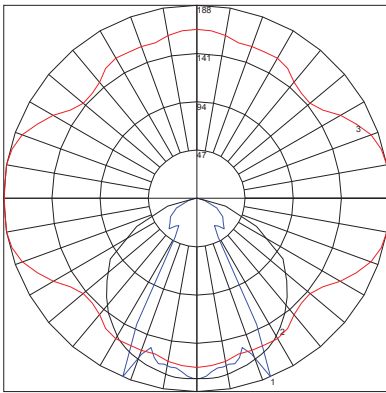

NOYES WITH CLEAR LENS
Lumens per foot: 304.28
Watts per foot: 4
CRI : 94.3
Peak Candela: 175.47

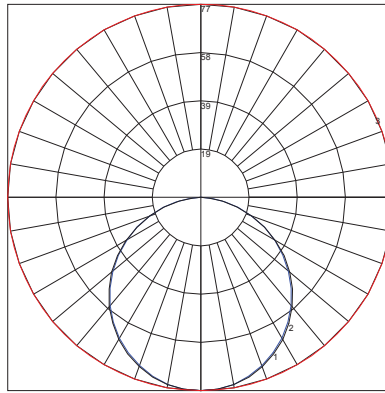

NOYES WITH DIFFUSED LENS
Lumens per foot: 222.46
Watts per foot: 4
CRI : 94.9
Peak Candela: 77.12

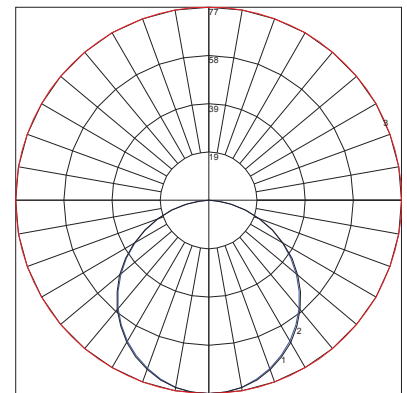

NOYES WITH OPAL LENS
Lumens per foot: 107.10
Watts per foot: 4
CRI : 97.4
Peak Candela: 77.12

